



INSTALLATION MAINTENANCE

SLICER AX-S12BA

INSTALLATION

UNPACKING

Immediately on delivery unloading, please check whether machine packaging is eventually deteriorated and in this case make necessary reservations on signing the delivery note. You will then check the machine inside packaging and eventually contact immediately the carrier when it is damaged.

Prior to installation, test the electrical service to assure that it is in compliance with the specifications on the machine data plate ① .

ELECTRICAL

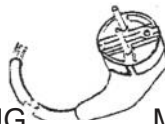
Warning: THIS MACHINE IS PROVIDED WITH THIS PLUG  MUST BE CONNECTED TO PROPERLY GROUNDING PLUG, GROUNDED OUTLET. IF THE RECEPTACLE IS NOT THE PROPER GROUNDING TYPE, CONTACT AN ELECTRICIAN.

CLEANING

This machine must be thoroughly cleaned and sanitized after installation and before being put into service.

SAFETY

SAFETY DEVICES INCORPORATED IN THIS SLICER MUST BE IN THEIR CORRECT OPERATING POSITION EVERY TIME THE SLICER IS IN USE.

The **blade cover** ⑥ must be in position over the knife and secured by tightening the hand knob ⑦.

The **last slice device** ④ must be used when slicing, it keeps your hands away from the knife.

When the slicer is not working, the **slicer thickness control** ② must be set on zero (fully clockwise) to prevent the blade edge from being exposed.

Always UNPLUG the power cord before cleaning or moving the slicer.

SLICING

Pull the **product holder** ③ towards you until it stops and place the product to be sliced on the **product holder tray**. Place the **last slice device** against the product and start the slicer by pressing the on-off switch ⑨. Adjust the slice thickness by turning the slice thickness **control**. The numbers on the **slice thickness control** do not indicate precise measurement, but may be used for reference to duplicate slice thickness. Using either the **carriage handle** ⑬ or **last slice device** ④ push the **product holder** ③ back and forth to slice. Always switch-off the slicer and turn the **slice thickness control** clockwise to zero when not slicing.

WARNING: Slicer should not be operated by untrained personnel or persons under 18 years of age.

CLEANING

This machine must be thoroughly cleaned after each day's operation or every time it will not be used for an extended period.

WARNING: UNPLUG MACHINE POWER CORD AND TURN THE INDEX KNOB FULLY CLOCKWISE BEFORE CLEANING THE SLICER.

Remove the **slice deflector** ⑫ by removing its thumb screw.

The **product holder** can be removed for an easy cleaning by unfastening its handle ⑧.

Using a mild soap and hot water solution and a clean cloth, wipe all surfaces of the slicer.

Thoroughly rinse it with another clean cloth and fresh water.

Remove the **blade cover** by removing the hand knob ⑦. With the hand knob removed, grasp the edge of the **blade cover** and carefully lift it straight off the knife.

WARNING: THE SLICER **BLADE** IS VERY SHARP USE EXTREME CAUTION WHEN WORKING NEAR THE **BLADE**.

CAREFULLY wash both sides of the **blade** with the **slice thickness control** turned fully clockwise. Wash the **blade** by wiping outward from the center. ALWAYS rinse the **blade** thoroughly using fresh water and a clean cloth. Never use steel pads to clean the **blade**. Wash and thoroughly rinse the removed components prior to reassembling them. DO NOT wash any slicer components in a dishwasher.

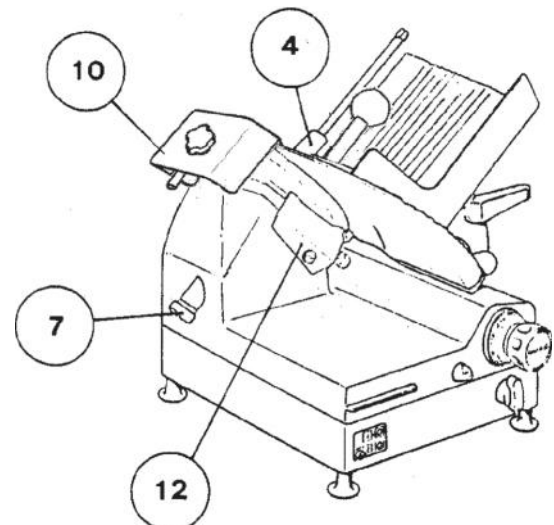
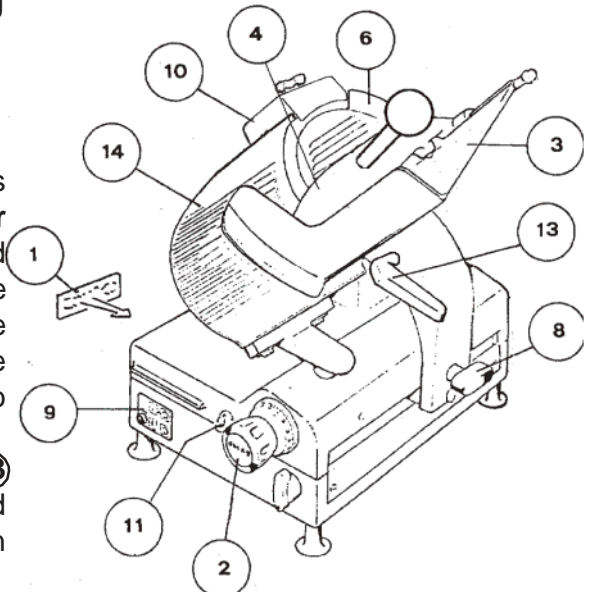

MAINTENANCE

ATTENTION
Use protection gloves

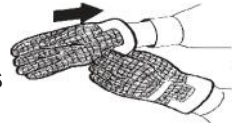

ELECTRICAL SAFETY

When the slicer is running the eventual removal of the blade cover (6), or the default of electric power, causes the stop of the machine.

To restart the slicer press the on-off switch (9).

SHARPENING OPERATION

Your slicer **blade** will provide long service in normal deli, food store, or commercial kitchen use.

However, in high volume applications where it is a practice to sharpen the **blade** frequently or even daily, the **blade** will be expended in a shorter time.

For a correct sharpening of the blade follow these instructions:

- 1 Make sure that the machine is off.
- 2 Clean the blade removing any greasy residue.
- 3 Rotate the slice thickness control to zero to make sure that the blade is covered by the slice thickness plate.

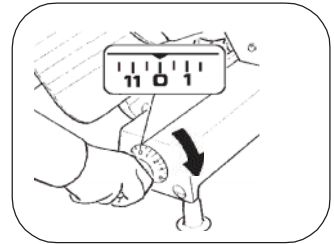

ATTENTION

During the sharpening operations, pay attention to an accidental contact with the blade.

- 4 Fully lift up and turn it by 180° the sharpener device
- 5 Press the grinding wheel pushbutton and put back in its place the sharpener device.
- 6 **Sharpening:** Press pushbutton to start the machine and start the automatic sharpening operation. After 10 max. 15 seconds press the honing stone button and push the wheel towards the blade. After a few seconds, with the two wheels in contact with the blade, press the stop pushbutton
- 7 Lift and rotate of 180° the sharpener and reset it into its initial position

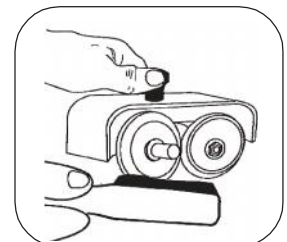
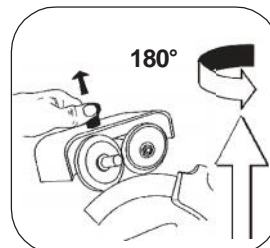
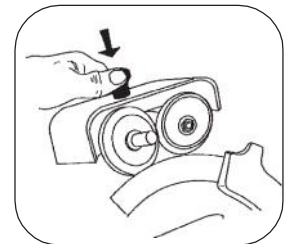
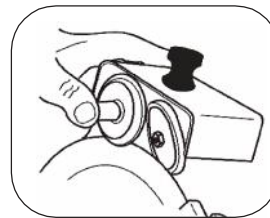
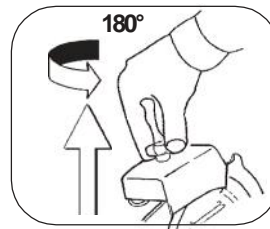

Cleaning of the grinding wheels

For an adequate sharpening the grinding wheel must always be cleaned. Remove dirt and grease with alcohol by using a brush.

DEFINITIONS

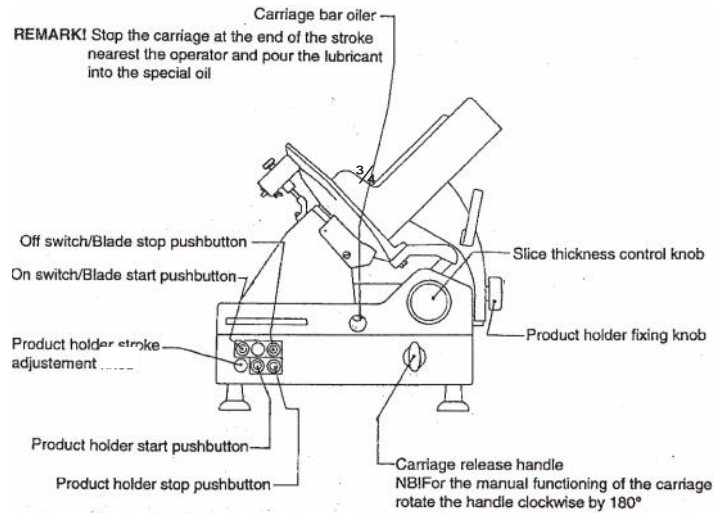

MANUAL OPERATION

Rotate the AUTO/MANUAL selector carriage release handle by 180°, clockwise
 Push the on switch/blade start pushbutton
 Adjust the thickness you want by turning the slice thickness control knob
 Actuate the carriage by your hand
 Push the off switch/blade stop pushbutton

AUTOMATIC OPERATION

Rotate the AUTO/MANUAL selector carriage release handle by 180°, counterclockwise
 Push the on switch/blade start pushbutton
 Adjust the thickness you want by turning the slice thickness control knob
 Push the product holder start pushbutton
 Adjust the length of the stroke by turning the product holder stroke adjustment
 Push the product holder stop pushbutton to end carriage movement
 Push the off switch blade stop pushbutton

LUBRICATION

The rod on which the **product holder** slides, which is underneath the slicer, should be lubricated weekly with several drops of oil. Stop the carriage at the end of the stroke nearest the operator position and pour the lubricant into the special oiler. **DO NOT** use vegetable oil. Occasionally, the slice thickness plate slide rod should be coated lightly with lubricant. Turn the slice thickness control fully counterclockwise when lubricating this slide rod and then turn it fully clockwise when finished. **DO NOT** lubricate the rod on which the **last slice device slides**. It must be kept clean but not lubricated. The motor has sealed bearings and requires no lubrication maintenance.

WEAR ADJUSTMENT

After several years of operation and many sharpenings of the **blade** it may become necessary to have the slice **thickness plate 14** adjusted closer to the blade.

Motors electrical data

W	V	Hz	Phase N°	Service	A	IP Degree of Protection
390	230	50	1~	S1	7	33
	220	60				
	120	60				

Slicing capacity mm

GLM 300	
A	170
B	210
C	240
D	210

