

Control Wiring
208 - 240 VAC
60HZ

LEGEND

lb= light blue
blk= black
pk= pink

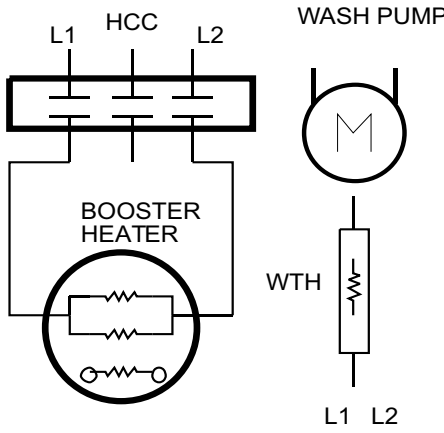

- TB: terminal block, (control wiring)
- NFC: audio filter (electrical noise distortion)
- DP: drain pump
- SW2: switch activate drain pump
- PS: pressure switch, control water level
- SV: solenoid valve
- DS: door switch
- SW1: cycle switch (start switch)
- CR: control relay with two normally open contacts
- CR1: normally open contact of (CR)
- CR2: normally open contact of (CR)
- TM: timer motor
- TS1: timer microswitch (TM)
- TS2: timer microswitch (TM)
- TS3: timer microswitch (TM)
- WP: wash pump
- R-THS: rinse thermostat
- W-THS: wash thermostat
- HCC: booster heater contactor
- WTH: wash heater element
- LP1: power on-off indicator light
- LP2: ready indicator light
- LP3: cycle indicator light
- C: capacitor
- TG: temperature gauge

TIMER PROGRAM

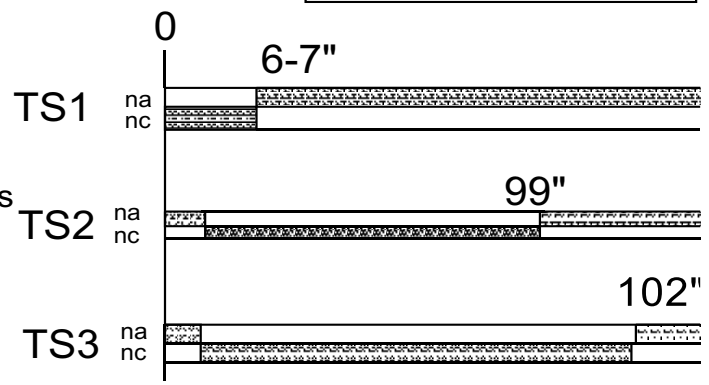

na=normally open
nc=normally close

H4P 1N3 Can

737 DP