



**AX-M40
40 QUART MIXER**

PROJECT _____
ITEM # _____
QUANTITY _____



AX-M40 40 QUART MIXER

The Axis Model AX-M40 is an advanced design, highly reliable professional food processing tool, and is ideal for mixing all types of dough, as well as eggs, cream, mayonnaise, etc. These all-purpose mixers use a powerful, planetary mixing action to thoroughly blend, mix and aerate all ingredients with consistent and predictable results.

STANDARD FEATURES	STANDARD ACCESSORIES
<ul style="list-style-type: none"> ★ 1.5 HP motor ★ Reliable and dependable gear drive design ★ Digital timer (0-30 min) ★ 3 speeds ★ Heat-treated hardened alloy steel gears and shaft 	<ul style="list-style-type: none"> ★ 40 Quart S/S bowl ★ Aluminum flat beater ★ S/S wire whip ★ Aluminum dough hook
<ul style="list-style-type: none"> ★ Stainless steel bowl guard ★ Side mounted controls (Timer, separate start and emergency stop button) ★ Silent operation ★ Highest quality aluminum alloy used for maximum standards of hygiene 	<p>OPTIONAL ACCESSORIES</p> <ul style="list-style-type: none"> ★ VS Attachment (<i>housing only</i>) ★ Disks avail. for VS Attachment: (Shredder, grater and slicer disks) <i>Sold separately</i> ★ Meat mincer attachment



Model	Capacity	Motor	Amps	Speeds	Electrical
AX-M40	40 Quart	3 Speeds	12	113/233/427	220v / 60hz / 1ph

TECHNICAL DRAWING

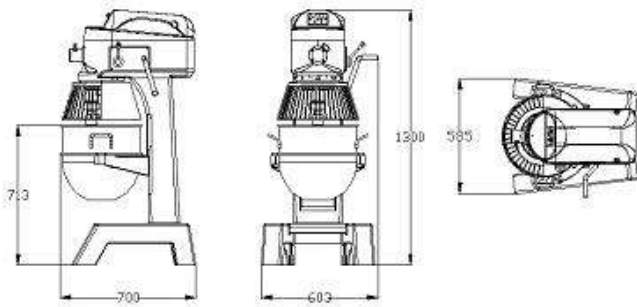

DIMENSIONS

Overall Width = 23.7" (603mm)
Overall Depth = 27.5" (700mm)
Overall Height = 51.1" (1300mm)

WEIGHT

NET = 441 lbs
SHIP = 510 lbs

FREIGHT CLASS = 77.5

SPECIFICATIONS

★ Design

Heavy duty all purpose mixers use a powerful, planetary mixing action to thoroughly blend mix and aerate all ingredients with consistent results.

★ Stainless Steel Bowl Guard

Safety interlock prevents operation when front portion of guard is open.

★ Three Fixed speeds

Consistency, flexibility and reliability. Excellent for incorporating, blending and mixing ingredients. Provides consistent results throughout mixing.

★ Gear Transmission

Ensures consistent performance and minimum downtime under heavy loads.

★ 1.5 H.P. Motor

Meets the most demanding operations.

★ Electronic Digital Timer

Provides accurate and consistent results while indicating the length of mixing (in minutes) on digital timer.

★ Warranty

2 year parts and 1 year labor, exclusive of wear items

Due to our continued product improvement and striving for engineering excellence, specifications are subject to change without notice

MVP GROUP CORPORATION

5659 Royalmount Ave. Montreal, QC Canada H4P 2P9
Tel: 514-737-9701 888-275-4538 Fax: 514-342-3854
www.mvpgroupcorp.com / sales@mvpgroupcorp.com