



MODELS

KGL-OF-(40, 50, 60)-S
KGL-OF-(40, 50, 60)-R

GRAB-N-GO LOW
PROFILE CASE

- Case holds 36°F to 40°F • Forced air refrigeration • Open front
- Front loading LED lighting in canopy and under all shelves
- Pull down night curtain • Cases can be multiplexed



SELF CONTAINED	Model	O.A. Length Inches	Volume FT ³	Electrical - 115 volts						NEMA 115V Plug	Weight LBS.		Crate Size		
				Compressor			Lights Fans HTRS	Evap Pan	Total Amps		No Crate	With Crate	"L"	"W"	"H"
				H.P.	F.L.A.	L.R.A.									
				Front											
	KGL-OF-40-S	41	12.98	5/8	8.9	47	0.85	6.7	16.42	5-20-P	357	507	43-3/4	34-1/2	67-3/4
	KGL-OF-50-S	50-1/8	16.21	3/4	16	64	1.33	6.7	24.00	--	394	569	53	34-1/2	67-3/4
	KGL-OF-60-S	60-5/8	19.85	3/4	16	64	1.39	6.7	24.06	--	454	653	63-1/2	34-1/2	67-3/4

REMOTE	Model	O.A. Length Inches	115 Volts Total Amps	B.T.U.	Weight LBS.					
					No Crate	With Crate				
					KGL-OF-40-R	41	0.40	4125	291	441
					KGL-OF-50-R	50-1/8	0.43	4897	317	491
KGL-OF-60-R	60-5/8	0.49	5141	376	575					

STANDARD FEATURES

- Insulation-CFC free injected foam
- Interior-PVC coated steel gray
- Silver colored PVC coated steel front panel with black steel kick plate
- Foamed polystyrene black end panels
- Height adjustable shelves can be tilted
- Product stops on all shelves
- Temperature and defrost regulated by a digital controller
- Slide out condensing unit on self-contained units
- Removable condensate evaporative pan for easy cleaning on S/C only
- Cord and plug KGL-OF-40-S only
- Levelling feet

OPTIONAL FEATURES

- Stainless steel exterior
- Stainless steel interior
- Other colors available
- Additional shelves
- Price tag molding
- Condensate evaporative pan for remote cases
- Casters-add 4-3/8" to height
- Stainless steel legs are adjustable from 5-1/8" to 7-5/8"

WARRANTY

One year parts and labor with an additional four years on the compressor (part only)

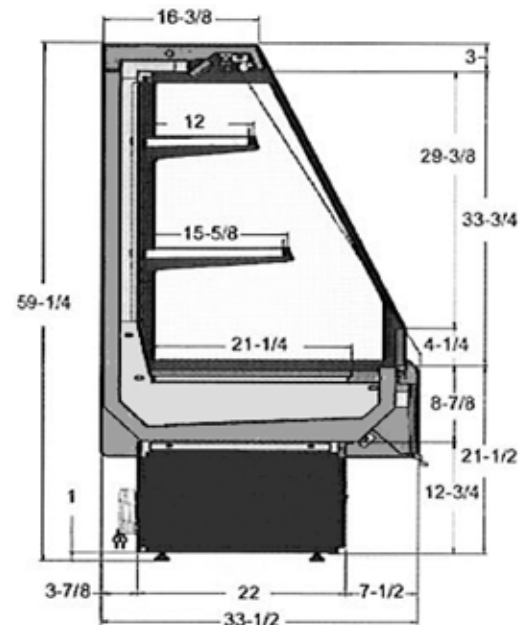

NOTE

These cases are engineered to operate in locations not exceeding 75°F and 55% R.H. These cases are designed to operate using R404a refrigerant. Alternate refrigerants available by special order. O.A. length includes (2) ends at 1-7/8" each. Ventilation grills at front and back cannot be blocked. B.T.U.'s are calculated at 14°F (evaporator) and 90°F (ambient). Remote cases are provided with an expansion valve and a liquid solenoid for pump down cycle. On remote cases, if no floor drain is provided, a condensate evaporating pan must be ordered and 6.7 amps added to the amp load. Some self-contained and all remote cases must be hard wired – no plugs.

USA Tel: 786.600.4687 / Toll Free: 844.218.8477
Fax: 786.661.4100

Canada Tel: 514.737.9701 / Toll Free: 888.275.4538
Fax: 514.342.3854 / Toll Free: 877.453.8832

sales@mvpgroupcorp.com / mvpgroupcorp.com