



PROJECT NAME: _____

LOCATION: _____

ITEM: _____ QTY: _____

MODEL: _____

SRF-40/50

TUBE FIRED GAS FRYER

The Sierra all-purpose fryers feature outstanding reliability and durability, capable of cooking a wide variety of fried foods with consistent uniformity and great taste.

Three, highly efficient tube fired, cast iron burners create a large heat-transfer area for reliable, even heat distribution. Our durable temperature probe senses temperature changes and activates a quick burner response. The temperature for the SRF-40/50 ranges from 200°F (93°C) to 400°F (204°C). Includes Millivolt safety control system.

Every inch of the frypot and cold zone can be cleaned and wiped down by hand. The large cold zone and forward sloping bottom help collect and remove sediment from the frypot to safeguard oil quality and support routine frypot cleaning.

6" swivel casters are optional.



TUBE FIRED



Delivering heat through tube burners of 16 gauge stainless steel for rapid temperature recovery

STANDARD FEATURES

- Welded **16 gauge** stainless steel tank with a super smooth machine finish ensures easy cleaning
- Stainless steel front, door and sides, with a galvanized back
- Long lasting baffles are mounted in the 3 heat exchange tubes to provide maximum heating and combustion efficiency
- Standing pilot light design provides a ready flame when heat is required
- Integrated gas control valve acts as a manual and pilot valve, automatic pilot valve, gas filter, pressure regulator and automatic main valve
- Robertshaw snap action millivolt thermostat control adjusts from 200°F-400°F. No electrical hookup required.
- Hi-limit shut-off protector shuts off gas combination valve and standing pilot.
- Built-in heat deflector
- Two nickel chrome plated oblong wire mesh baskets, with vinyl coated heat protection handles
- One nickel chrome plated tube rack and drain extension
- 6" adjustable stainless steel legs
- The SRF-40/50 is shipped from the factory, ready for natural gas installation. An LP conversion kit is included with each unit.



Tel.: 786.600.4687 / Toll Free: 844.218.8477
Fax: 786.661.4100



Tel.: 514.737.9701 / Toll Free: 888.275.4538
Fax: 514.342.3854 / Toll Free: 877.453.8832
sales@mvpgroupcorp.com

MVP
GROUP

www.mvpgroupcorp.com

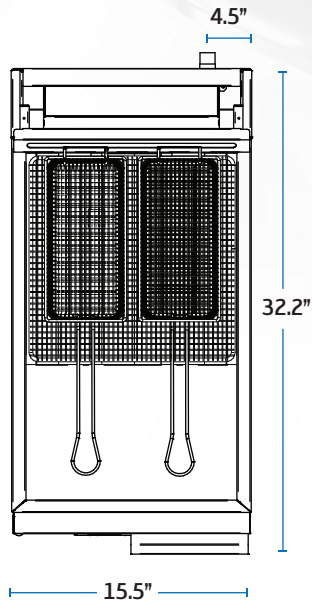

SPECIFICATIONS

MODEL NUMBER	SRF-40/50
EXTERNAL DIMENSIONS (WxDxH) INCLUDING HANDLE	15.5" X 32.2" X 44.4"
NUMBER OF BURNERS	3
FRYER CAPACITY	45 - 50 LBS
BTU (EACH BURNER AT 5" W.C)	38,000
TOTAL BTU	114,000
NET WEIGHT	152 LBS
SHIPPING WEIGHT	167 LBS

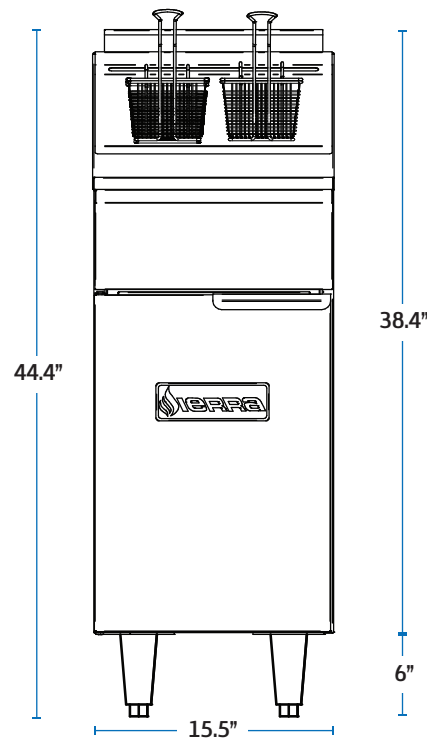
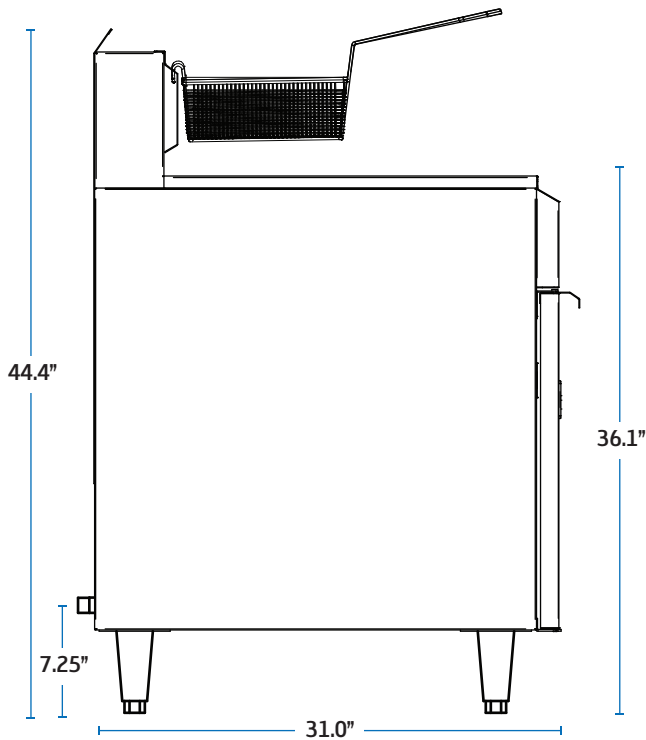

Warranty: 12 months parts & labor. Additional fry tank warranty to the original purchaser only: If the fry tank has leaked because of a manufacturing defect, as confirmed by an MVP Group servicer within the first two years of operation, MVP Group shall replace the fryer. Refer to Operators Manual for full details. Freight or installation charges shall not be included.

Gas Connection: 3/4" NPT on the right-hand rear of the appliance. The pressure regulator (supplied) is to be connected here by the installer.
Gas pressure: 4" W.C. - Natural Gas | 10" W.C. - Propane

Clearances: Combustible: 6 inches sides, 6 inches rear, 16 inches to adjacent open flame burner units | **Non-combustible:** 0 inches sides, 0 inches rear, 16 inches to adjacent open burner flame units. Specify type of gas and altitude, if over 2,000 feet, when ordering.



SIERRA RANGE is a registered trademark of **MVP Group**.

Due to continuing product development, to ensure best possible performance, the specifications are subject to change without prior notice.



Tel.: 786.600.4687 / Toll Free: 844.218.8477
 Fax: 786.661.4100



Tel.: 514.737.9701 / Toll Free: 888.275.4538
 Fax: 514.342.3854 / Toll Free: 877.453.8832
 sales@mvpgroupcorp.com