



MODELS

KGV-MD-(2, 3)-R

HIGH VOLUME GRAB-N-GO CASE
FOR REMOTE CONDENSING UNIT

- Case holds 33°F to 40°F • Forced air refrigeration • 2 and 3 door models
- Front loading • LED lighting in canopy and under all shelves
 - Cases can be multiplexed



REMOTE	Model	No. of Doors	O.A. Length Inches	Volume FT ³ Front	Total Amps	B.T.U.'s	Weight LBS.		Crate Size		
							No. Crate	With Crate			
									'L'	'W'	'H'
	KGV-MD-2-R	2 X 23-1/2	51-1/2	37.63	1.43	3445	555	763	54	37	85
	KGV-MD-3-R	3 X 23-1/2	75-3/8	56.37	2.19	4430	773	1040	78	37	85

NOTE: FOR OTHER LENGTHS, PLEASE CONTACT MVP

STANDARD FEATURES

- Insulation-CFC free injected foam
- Interior-PVC coated steel gray
- Silver colored PVC coated steel front panel with black steel kick plate
- Foamed polystyrene black end panels
- Height adjustable shelves can be tilted
- Product stops on all shelves
- Temperature and defrost regulated by a digital controller
- Levelling feet

OPTIONAL FEATURES

- Other colors available
- Stainless steel exterior
- Stainless steel interior
- Additional shelves
- Price tag molding

WARRANTY

One year parts and labor with an additional four years on the compressor (part only)

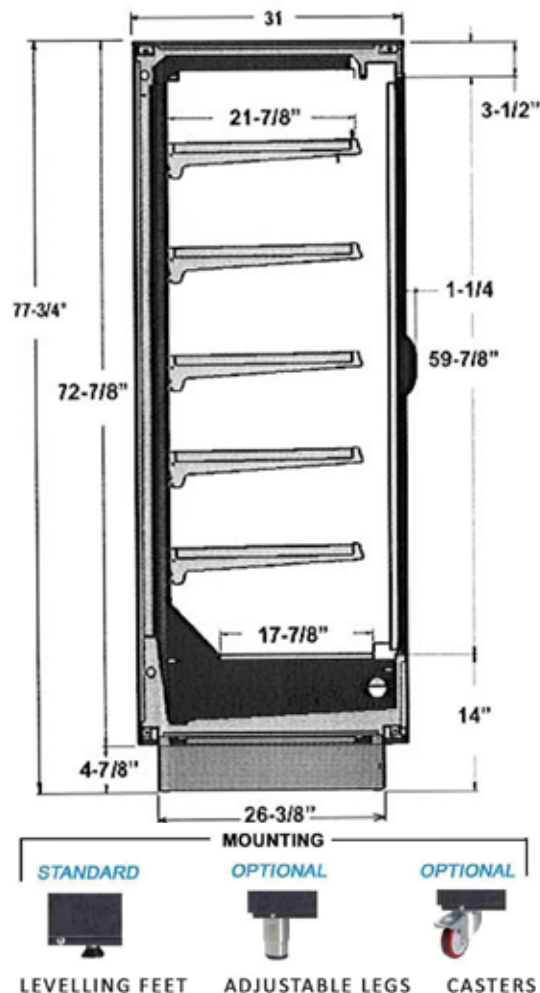

NOTE

These cases are engineered to operate in locations not exceeding 75°F and 55% R.H. These cases are designed to operate using R404a refrigerant. Alternate refrigerants available by special order. O.A. length includes (2) ends at 1-7/8" each. Ventilation grills at front and back cannot be blocked. B.T.U.'s are calculated at 14°F (evaporator) and 90°F (ambient). Floor drain must be provided. Remote cases are provided with an expansion valve and a liquid solenoid for pump down cycle. Cases must be hard wired – no plugs.