



MODELS

KFM-SF-(40, 50, 60, 80, 100, 120)-S

KFM-SF-(40, 50, 60, 80, 100, 120)-R

FLAT GLASS SEAFOOD CASE
WITH ICE PANS

Case holds 33°F to 40°F • Low velocity forced air refrigeration maintains high humidity • Tempered tilt-out flat front glass • Tempered side glass and rear sliding doors • Cases can be multiplexed
• Cases require floor drains



SELF CONTAINED	Model	O.A. Length Inches	Volume FT ³	Electrical - 115 volts					NEMA 115V Plug	Weight LBS.		Crate Size		
				Compressor			Lights, Fans,	Total Amps		No Crate	With Crate			
				H.P.	F.L.A.	L.R.A.						'L'	'W'	'H'
	KFM-SF-40-S	40-3/8	15.35	3/8	8.4	43	0.95	9.35	5-15P	350	512	48	44	42
	KFM-SF-50-S	52-1/8	20.22	1/2	9.6	49	0.96	10.56	5-15P	399	582	59	44	42
	KFM-SF-60-S	60	23.47	1/2	9.6	49	1.08	10.66	5-15P	452	650	67	44	42
	KFM-SF-80-S	77-1/2	30.70	5/8	8.9	47	1.68	10.58	5-15P	562	825	85	44	42
	KFM-SF-100-S	101-1/8	40.45	3/4	16	64	1.81	17.81	N/A	697	974	109	44	42
	KFM-SF-120-S	117	46.95	3/4	16	64	2.06	18.06	N/A	831	1204	124	44	42

REMOTE	Model	O.A. Length Inches	115 Volts Total Amps	B.T.U.	Weight	
					No Crate	With Crate
	KFM-SF-40-R	40-3/8	0.5	2548	295	456
	KFM-SF-50-R	52-1/8	0.51	3015	344	526
	KFM-SF-60-R	60	0.63	3159	397	595
	KFM-SF-80-R	77 1/2	0.78	4345	529	791
	KFM-SF-100-R	101-1/8	0.91	5112	642	919
	KFM-SF-120-R	117	1.16	5472	765	1138

STANDARD FEATURES

- Insulation-CFC free injected foam
- Stainless steel interior
- Silver colored PVC coated steel front panel with black steel kick plate
- Foamed polystyrene black end panels
- Tempered tilt-forward front glass
- Removable rear tempered glass sliding doors
- LED lighting in canopy
- Temperature and defrost regulated by a digital controller
- Slide out condensing unit on S/C only
- Anti-condensate system for front glass
- Digital thermometer
- Levelling feet

OPTIONAL FEATURES

- Lift up front glass
- Stainless steel exterior
- Other colors available
- Scale stand with receptacle
- Cutting board
- Knife support
- Casters-add 4-3/8" to height
- Stainless steel legs are adjustable from 5-1/8" to 7-5/8"

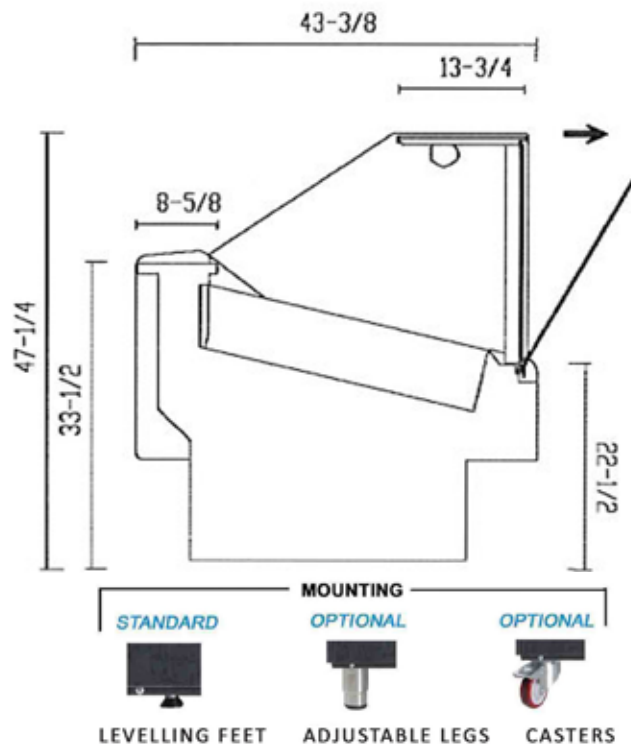

NOTE

These cases are engineered to operate in locations not exceeding 75°F and 55% R.H. These cases are designed to operate using R404a refrigerant. Alternate refrigerants available by special order. O.A. length includes (2) ends at 1-1/2" each. Ventilation grills at front and back cannot be blocked. B.T.U.'s are calculated at 14°F (evaporator) and 90°F (ambient). Remote cases are provided with an expansion valve and a liquid solenoid for pump down cycle. Remote cases must be hard wired – no plugs.

 Tel: 786.600.4687 / Toll Free: 844.218.8477
Fax: 786.661.4100

 Tel: 514.737.9701 / Toll Free: 888.275.4538
Fax: 514.342.3854 / Toll Free: 877.453.8832

sales@mvpgroupcorp.com / mvpgroupcorp.com

