













### After a power outage

After a power outage unplug the refrigerator and wait at least 5 minutes before plugging in and restarting the refrigerator



### No medicine

Medicines should not be stored inside the refrigerator.



## Use and Caution

### 1. Before use:

Plug the refrigerator in a dedicated outlet designed for the power rating of the unit.



This appliance is not intended for use by unauthorized individuals as well as individuals with reduced physical, sensory or mental capabilities, or lack of experience and knowledge, unless they have been given supervision or instructions concerning the use of the appliance by a person responsible for their safety. Children should be supervised to ensure that they do not play with the appliance.

### 2. Digital Temperature controller

Front Panel Operation

#### 1. Set temperature

Press the set button, the default temperature that is currently set at will be displayed.

Press  or  button to modify and store the modified value.

Press the set button, this will save the new temperature

If for 10 seconds there is no response, the temperature will revert back to the default settings.

#### 2. Lights: Press button, if the lights turn on ; Press again, and they will turn off.

Manually start/stop the defrost : Press  button and hold for 6 seconds to start the defrost or stop the defrost.

#### 3. Defrost LED: As the unit is cooling, the LED will stay on. When the temperature of the unit is at the set temperature the LED will be off. If there is a delay in the start then the LED will flash.

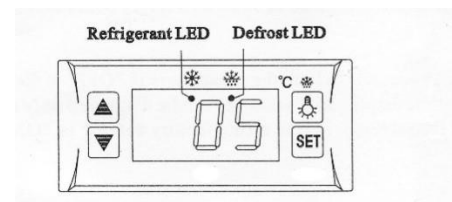

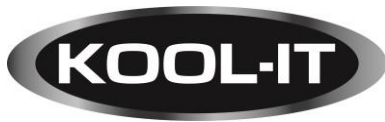

### Maintenance

1. The product needs to be cleaned once a week with the power supply disconnected. While cleaning please use a mild rinsing water or non-corrosive detergent. Do not wash it directly with water.
2. Cleaning for filter  
To keep the device in good working condition, the condenser needs to be cleaned every month. When the message “EE4” appears on the display, please clean the condenser immediately. After cleaning, if message “EE4” appearing again, please contact service.
3. Check if the unit is leaking. Observe all the connectors and welding joints for any oil stains. If there are any oil stains call service.
4. Frequently observe the operation of the product. In case of any abnormal noise, smell or smoke, cut off the power supply immediately and call for service  
. Do not restart the product before the issue has been rectified.
5. MVP Group will not be liable for any accident incurred or failures that occurs due to actions that do not follow the guidelines indicated in the manuals.

### Troubleshooting

	Causes	Solutions
Strange noise under the bottom shelf	Fan blade broken	Call Service, the fan blade needs to be replaced.
Unit is not getting cold.	<ol style="list-style-type: none"> <li>1. Unit is off.</li> <li>2. Refrigerant leaking</li> <li>3. Unit has failure</li> </ol>	Call Service
Defrost Water overflowing	<ol style="list-style-type: none"> <li>1. Heating tube is damaged</li> <li>2. Water-level controller failure</li> <li>3. Ambient temperature or humidity is above the recommended settings.</li> </ol>	<ol style="list-style-type: none"> <li>1. Replace the heating tube</li> <li>2. Replace the water-level controller</li> <li>3. Improve the conditions</li> </ol>
Normal air curtain, but periodical fluctuation of cabinet temperature	<ol style="list-style-type: none"> <li>1. Condenser contaminated</li> <li>2. Poor venting of the unit</li> <li>3. Heat protection of compressor failure</li> <li>4. Capillary is blocked by ice</li> <li>5. Temperature controller failure</li> </ol>	<ol style="list-style-type: none"> <li>1. Clean the condenser</li> <li>2. Improve the venting conditions</li> <li>3. Replace the heat protection</li> <li>4. Replace the filter</li> <li>5. Replace the temperature controller</li> </ol>

### Note

The murmur of water is heard when the refrigerator is working. It is a normal occurrence as the coolant is circulating in the system. Condensation might be found on the outside of the refrigerator. This is caused by high humidity. Simply use a cloth to wipe it.



5659 Royalmount Ave.  
 Montreal, QC, Canada H4P 2P9  
 Telephone: 514.737.9701 / Toll Free: 888.275.4538  
 Fax: 514.342.3854 / Toll Free: 877.453.8832  
[sales@mvpgroupcorp.com](mailto:sales@mvpgroupcorp.com) / [mvpgroupcorp.com](http://mvpgroupcorp.com)

12000 Biscayne Blvd., Suite # 108  
 Miami, FL, United States 33181  
 Telephone: 786.600.4687 / Toll Free: 844.218.8477  
 Fax: 786.661.4100



## Circuit Diagram

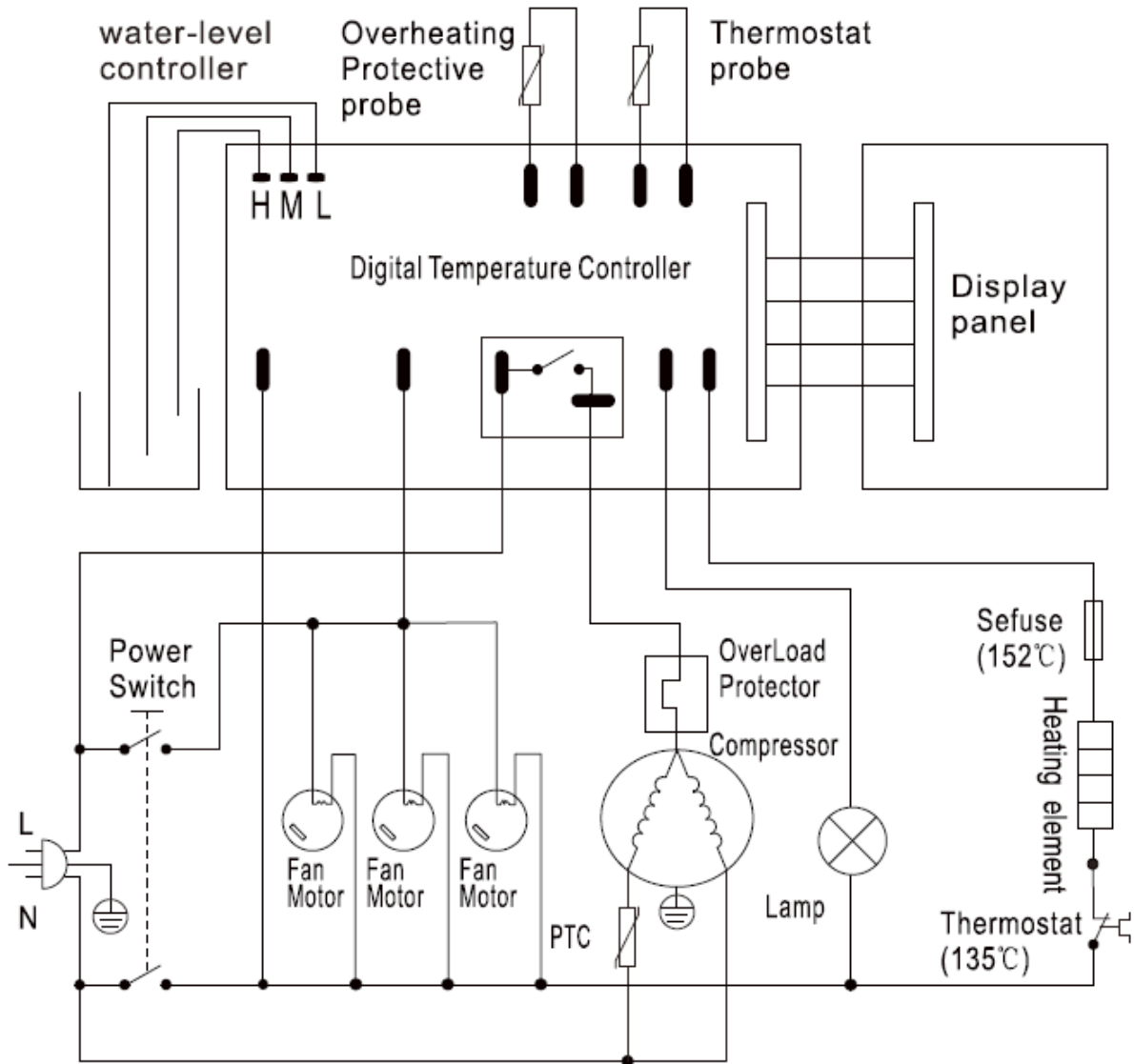

5659 Royalmount Ave.  
Montreal, QC, Canada H4P 2P9  
Telephone: 514.737.9701 / Toll Free: 888.275.4538  
Fax: 514.342.3854 / Toll Free: 877.453.8832  
sales@mvpgroupcorp.com / mvpgroupcorp.com

12000 Biscayne Blvd., Suite # 108  
Miami, FL, United States 33181  
Telephone: 786.600.4687 / Toll Free: 844.218.8477  
Fax: 786.661.4100